



TOLDOS ARTICULADOS



Especificaciones Generales

(Para nuestros 3 modelos articulados)

1	Tiempo de armado	1,5 minutos o menos.
2	Largo (cerrado)	2.1 metros
3	Materialidad Estructura	Aluminio
4	Tela / géneros	Canvas Ripstop 320 gr/m2
5	Impermeabilidad	3.000 mm de c.a.
6	Free Standing	Sí (Instalación sin pilares)
7	Resistencia UV	Sí



NUESTROS MODELOS DE TOLDOS ARTICULADOS

4 BRAZOS 180°

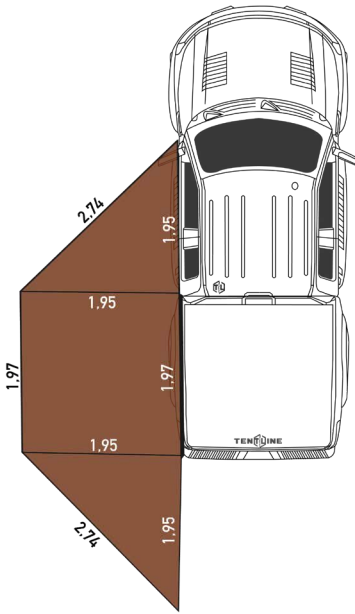

Peso 21 Kgs

Sombra 7.7 m²

4 BRAZOS 270°

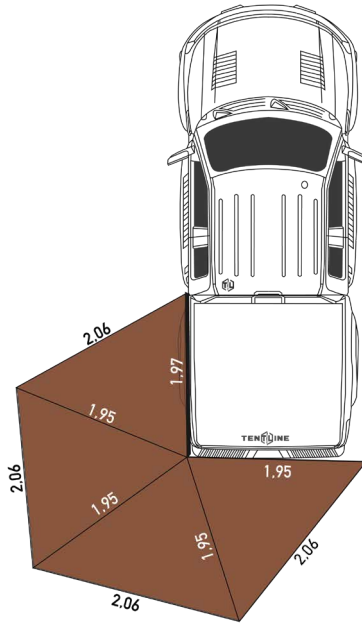

Peso 21 Kgs

Sombra 6.0 m²

6 BRAZOS 270°

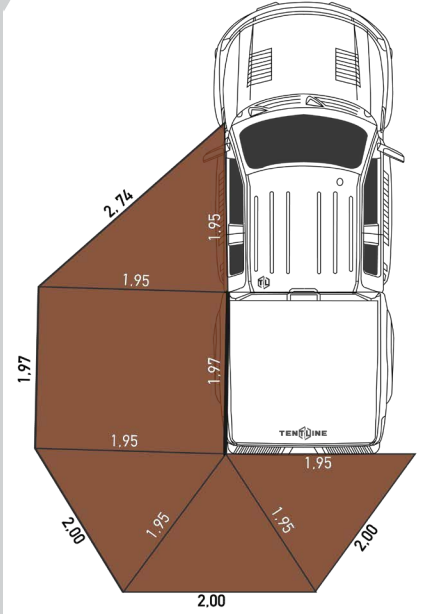

Peso 32 Kgs

Sombra 14.3 m²

*MEDIDAS EN METROS

COMPATIBILIDAD CON ACCESORIOS



✔ Cierre perimetral total para modelos 270

✔ Extensiones de toldo unitarias a piso

